

Primer on Medical Genomics Part VIII: Essentials of Medical Genetics for the Practicing Physician

REGINA E. ENSENAUER, MD; SHANDA S. REINKE, MS; MICHAEL J. ACKERMAN, MD, PhD;
DAVID J. TESTER, BS; DAVID A. H. WHITEMAN, MD; AND AYALEW TEFFERI, MD

After the mapping and sequencing of the human genome, medical professionals from essentially all specialties turned their attention to investigating the role genes play in health and disease. Until recently, medical genetics was considered a specialty of minor practical relevance. This view has changed with the development of new diagnostic and therapeutic possibilities. It is now realized that genetic disease represents an important part of medical practice. Achievements in cancer genetics, in the field of prenatal diagnostics (including carrier testing for common recessive disorders), and in newborn screening for treatable metabolic disorders reinforce the rapidly expanding role of genetics in medicine. Diagnosing a genetic disorder not only allows for disease-specific management options but also has implications for the affected individual's entire

family. A working understanding of the underlying concepts of genetic disease with regard to chromosome, single gene, mitochondrial, and multifactorial disorders is necessary for today's practicing physician. Routine clinical practice in virtually all medical specialties will soon require integration of these fundamental concepts for use in accurate diagnosis and ensuring appropriate referrals for patients with genetic disease and their families.

Mayo Clin Proc. 2003;78:846-857

AS = Angelman syndrome; FISH = fluorescence in situ hybridization; mtDNA = mitochondrial DNA; PKU = phenylketonuria; PWS = Prader-Willi syndrome; UPD = uniparental disomy

Genetic disease is not as rare as once believed. In fact, genetic disease is a major cause of illness and death. Approximately 2% to 3% of all pregnancies result in a neonate with a serious genetic disease or a birth defect that can cause disabilities, mental retardation, and in some cases early death.¹ The British Columbia Health Surveillance Registry, created in 1952, has provided estimates of the frequency of genetic disease.² Analysis of data derived from more than 1 million consecutive livebirths showed that before 25 years of age, at least 53 of 1000 liveborn individuals had diseases with an important genetic component. If all congenital anomalies, including cases with an uncertain genetic etiology, were considered as part of the genetic population load, the frequency of genetic disorders in this population would be about 79 per 1000. However, these figures might be even higher because systematic screening of the entire population for each disorder has not

been performed, mild genetic conditions with few or no symptoms might not be diagnosed, and the contribution of genetic disease to miscarriage and disorders of middle and old age were not included.

Precise figures for the proportion of newborns who will develop adult disease with an important genetic component are still unavailable, but consideration of the frequency of adult cancer and other common adult conditions, such as diabetes mellitus and congestive heart failure, and recognition of a genetic susceptibility for such conditions allow speculation that a substantial proportion of the population may be affected directly by genetic disease.

Because of the chronic nature of many genetic diseases with severe long-term consequences, families often face substantial medical, financial, and emotional issues, which also affect society at large. Hall et al³ noted a genetic disorder in more than 1 in 4 of 4115 pediatric inpatients, and the hospital stay of these patients was longer than that for other pediatric inpatients. This figure does not take into account morbidity that did not lead to hospital admission. Additional burden is associated with the high prevalence of intellectual deficits seen in genetic conditions. Notably, more than one half of individuals with a learning disability may have an underlying genetic etiology.⁴

The commonly used term *nongenetic* appears to be ambiguous because it is unlikely that any disease is entirely nongenetic. The interaction of both genetic and environ-

From the Department of Medical Genetics (R.E.E., S.S.R., D.A.H.W.), Division of Cardiovascular Diseases and Internal Medicine (M.J.A.), Division of Pediatric Cardiology (M.J.A.), Department of Molecular Pharmacology and Experimental Therapeutics (M.J.A., D.J.T.), and Division of Hematology and Internal Medicine (A.T.), Mayo Clinic, Rochester, Minn.

This work was sponsored by the Mayo Clinic Genomics Education Steering Committee.

Individual reprints of this article are not available. The entire Primer on Medical Genomics will be available for purchase from the Proceedings Editorial Office at a later date.

mental factors influences the development of an individual. Genetic factors are present from conception, and their expression may vary throughout development, whereas environmental influences are changing constantly. Many conditions previously thought to be nongenetic are now understood to be multifactorial diseases with the contribution of various genetic and environmental determinants being recognized increasingly.

Genetically determined disorders often are subdivided into 3 major groups: chromosome, single gene, and multifactorial (polygenic) diseases. Somatic cell genetic defects play a role in human cancer and constitute a fourth group. The different types of genetic diseases may manifest clinically at different prenatal and postnatal ages (Figure 1).

CHROMOSOME DISORDERS

As a group, chromosome disorders are common, and with use of standard karyotype analysis via light microscopy, the frequency has been reported to be 6 in 1000 liveborn infants.⁶ Clinically important chromosome abnormalities account for about 1% of pediatric hospital admissions and 2.5% of childhood deaths.⁵ In nearly one half of spontaneous first-trimester abortions, major chromosome anomalies are found. Chromosome analysis in gametes reveals an estimated abnormality rate of 10% in sperm and 25% in oocytes.⁷ However, most conceptions with chromosome anomalies abort early, and thus the observed frequency of chromosome defects in term deliveries is much lower.

Some chromosome anomalies are "balanced" and include the full complement of genetic material in a rearranged form. Although balanced rearrangements have been associated with infertility and medical complications (perhaps because of breakpoints in important genes or secondary to positional effects of gene expression), most people with balanced chromosome rearrangements are healthy. In contrast, most individuals with a clinically important chromosome disorder have a net loss or gain of chromosome material and hence of genes. This can occur when an individual has a chromosome number other than the expected 46 (chromosome aneuploidy or polyploidy) or when a portion of a chromosome is altered (via a deletion or duplication).

Statistically, numerical chromosome abnormalities are the most common type of chromosome disorder. Chromosome aneuploidy occurs when there is other than a multiple of the typical haploid set. Although trisomy 16 is the most common autosomal trisomy in miscarriages, trisomies 21 (Down syndrome), 18 (Edwards syndrome), and 13 (Patau syndrome) are seen at considerable frequencies in newborns. Notably, the risk of having a newborn with any of these chromosome trisomies increases with maternal age, although not all chromosome aneuploidy is associated with maternal age. Turner syndrome (45,X) is most often caused

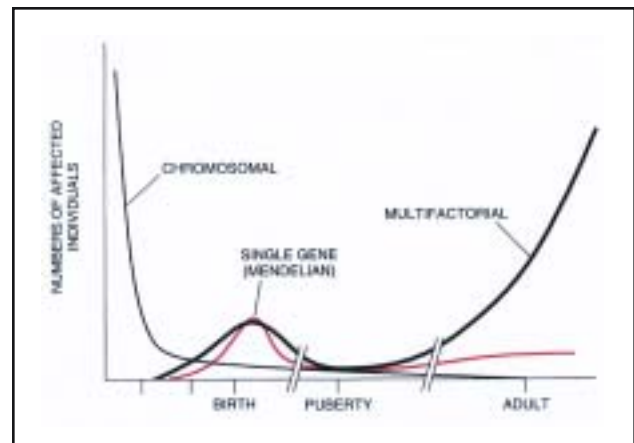

Figure 1. Age at manifestation of the different types of genetic disorders. Reprinted with permission from Gelehrter et al.⁵

by loss of the paternal X chromosome and is present in 1% of all conceptions; however, 98% result in miscarriage. Chromosome polyploidy occurs when the number of chromosome sets is other than 2. The most common type of chromosome polyploidy is triploidy (69 chromosomes), present in 1% to 3% of all conceptions. Triploidy is a sporadic occurrence and most commonly happens when 1 haploid egg is fertilized by 2 haploid sperm.

Another group of chromosome disorders includes those resulting in genetic imbalance despite retention of the normal number of 46 chromosomes. This group includes chromosome translocations in their unbalanced form, deletions, and duplications. In these situations, there is some net loss or gain of genetic material. There are numerous possible examples of this type of chromosome aberration. Although certain "hot spots" exist for chromosome alteration, virtually any chromosome could be affected in any position. Sometimes these events occur sporadically in the germline, sometimes a parent carries the same rearrangement, and sometimes a parent carries a balanced rearrangement that can result in offspring with an unbalanced karyotype.

Considering that several hundreds to thousands of genes comprise each chromosome, chromosome disorders such as those aforementioned typically manifest clinically with striking physical features, such as failure to thrive, mental retardation, and severe multisystemic abnormalities. Disorders such as trisomy 13, trisomy 18, and triploidy result in complications so severe that death usually occurs. The exact clinical spectrum associated with unbalanced chromosome rearrangements is extremely variable and depends on the magnitude of the imbalance and on the specific chromosomes (and hence genes) involved in the alteration.

Standard chromosome analysis using G-banding allows only the detection of relatively large structural rearrange-

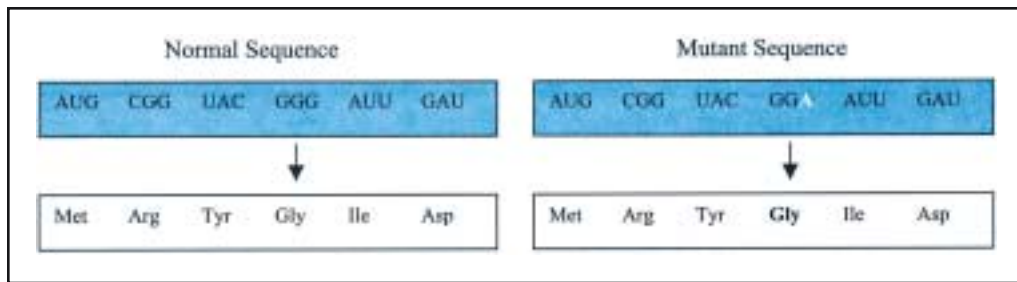

Figure 2. Synonymous (silent) mutation. Since the codons GGG and GGA encode for the same amino acid (glycine, Gly), this represents a silent mutation.

ments (3-4 megabases) and depends on the stage of band resolution. Because the subtelomeric areas of chromosomes are gene-rich, investigation of these regions for cryptic chromosome rearrangements has been of particular interest. Subtelomeric rearrangements can be identified by using specific molecular probes and fluorescence in situ hybridization (FISH). Initially, the frequencies of subtelomeric abnormalities in individuals with unexplained mental retardation detected by subtelomeric FISH were reported at 5% to 10%.^{8,9} However, recent studies suggest that the proportion of truly cryptic subtelomeric rearrangements is between 3% and 4%.^{10,11} Additional investigation is necessary to understand the frequency of this type of cryptic rearrangement in groups affected with certain medical/developmental complications.

SINGLE GENE DISORDERS

Single gene (monogenic) disorders are caused by alterations (mutations) in one or both alleles of a gene, involving changes at the nucleotide level that disrupt the normal function of a single gene product. Since the late 1970s, the number of disorders classified as single gene has increased from an estimated 2500 to approximately 14,000 (as of April 2003).¹² Of these 14,000 single gene disorders, 93.7% are classified as autosomal, 5.6% as X-linked, and 0.7% as other.¹² Considering that the human genome consists of approximately 30,000 genes,¹³ the number of diseases classified as monogenic is expected to increase. In time, the mounting compendium of gene alterations will be deciphered as to which variants/mutations contribute to monogenic disorders, which contribute to multifactorial genetic susceptibility to disease (pathogenomics) or pharmacological treatment of disease (pharmacogenomics), and which are clinically irrelevant.

Classification of Single Gene Mutations

Single gene mutations are classified into 3 basic categories: single nucleotide substitutions, deletions, and insertions.

Single Nucleotide Substitutions.—Single nucleotide substitutions, transitions and transversions, are the most common type of single gene mutation. Transitions are substitutions of a pyrimidine (cytosine [C] or thymine [T]) for a pyrimidine or a purine (adenine [A] or guanine [G]) for a purine. Transversions are substitutions of a pyrimidine for a purine or vice versa.^{14,15}

Further classification of single nucleotide substitutions can be made on the basis of how the nucleotide change affects the resulting protein structure.¹⁶ If a single nucleotide substitution occurs in the coding region (exon), the result may be a synonymous (silent) mutation (ie, a different codon that still specifies the same amino acid due to the degenerate nature of the genetic code), a nonsynonymous (missense) mutation (whereby the altered codon dictates a single different amino acid), or a nonsense mutation that terminates further protein assembly (ie, introduces a premature stop codon) (Figures 2-4). Importantly, the functional consequence and clinical implications of these different types of substitutions may be extremely variable.

The functional consequence of a missense mutation depends on the differences in biochemical properties between the amino acids that are being altered and/or the location in the protein at which the change occurs. Because a silent mutation does not change the amino acid structure of the protein, usually there are no functional consequences. However, these so-called silent mutations can display a functional phenotype through effects on splicing efficiency and gene expression. Such mechanisms are as yet poorly understood. With respect to nonsense mutations, the functional effects depend on the location of the premature stop codon and range from no detectable difference to functional lethality (a nonfunctioning protein). The extent and manner of protein modification govern the severity of the clinical phenotype.¹⁶

Base substitutions occurring in an intron (noncoding sequence) can also result in an altered gene product. The normal process whereby intronic sequences are excised from newly transcribed RNA to give a mature messenger

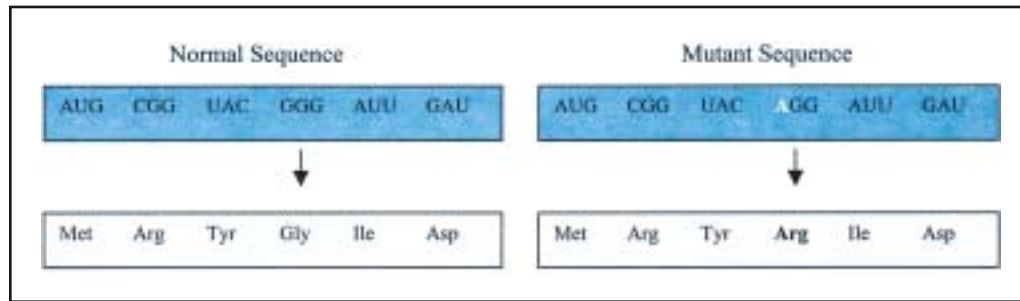

Figure 3. Nonsynonymous (missense) mutation. Since the codons GGG and AGG encode for different amino acids, this represents a missense mutation. The amino acid Gly (glycine) is now replaced by the new amino acid Arg (arginine).

RNA product (splicing) depends on specific nucleotide sequences located at the intron/exon (acceptor site) and exon/intron (donor site) boundaries. Base substitutions within these highly conserved regions can result in improper splicing of the immature RNA. In some cases, entire exons can be excised, or entire introns can be included in the mature messenger RNA.^{14,15} This alteration of the mature RNA transcript also causes differences at the protein level, which often result in clinical symptoms.

Deletions and Insertions.—Deletions are subtractions of nucleotides from the normal DNA sequence, and insertions are additions of nucleotides to the normal sequence (Figure 5). Both deletions and insertions can be as small as a single nucleotide or can involve many nucleotides.^{14,15}

Exonic insertions and deletions may alter the “reading frame” of RNA translation at the point of the deletion/insertion and give rise to a new sequence of amino acids in the finished product, a so-called frameshift mutation. Many frameshift mutations result not only in a different amino acid sequence from the point of the insertion or deletion onward but also often create a new stop codon that gives rise to either a shorter or longer gene product depending on the location of the new stop codon.

In-frame deletions and insertions can occur when the number of nucleotides affected is a multiple of 3. Perhaps

the most common in-frame mutation occurs in cystic fibrosis (the delta F508 mutation). Here, a 3 base-pair deletion in the *CFTR* gene results in an abnormal protein missing a single amino acid (phenylalanine at amino acid position 508). This single mutation accounts for nearly 70% of the mutant cystic fibrosis alleles examined to date.¹⁷

Polymorphisms.—Importantly, not all nucleotide changes create a new gene product that causes or modifies a clinical disease state. A DNA sequence variation that may (nonsynonymous) or may not (synonymous) alter the encoded protein is called a *common polymorphism* if present in at least 1% of the population. Although not necessarily pathogenic or disease causing, nonsynonymous single nucleotide polymorphisms can indeed be functional polymorphisms and exert an important effect by influencing responses to endogenous and exogenous stimuli. Rare gene variations (ie, allelic frequency <1%) can also be functionally relevant genetic determinants. These types of functional polymorphisms and variants are sought to explain the human variation observed with therapeutic and adverse-effect profiles of pharmaceutical agents (pharmacogenomics) or to account for the heterogeneous expression of disease in families harboring a disease-causing mutation in the same or other genes (ie, they may act as “modifier genes”). In addition, some types of polymorphisms are

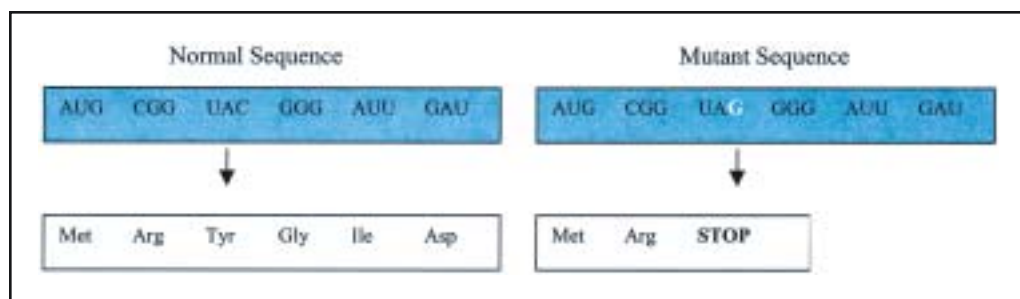

Figure 4. Nonsynonymous (nonsense) mutation. The C to G substitution (transversion) results in the premature introduction of a stop codon and thus a truncated protein.

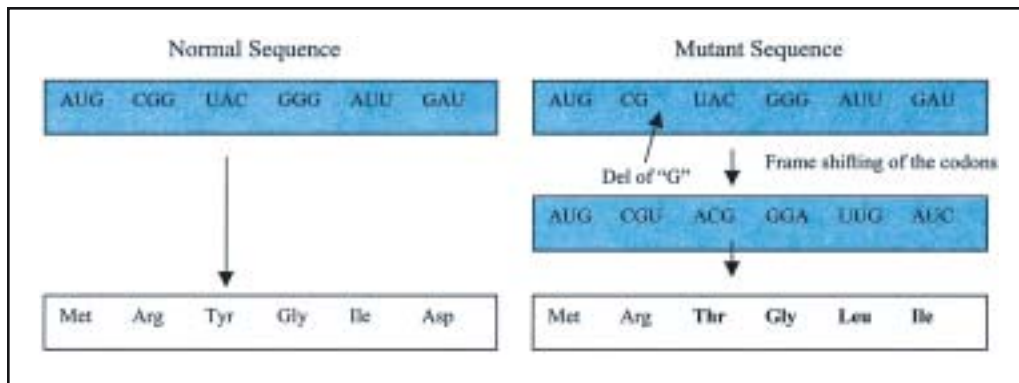

Figure 5. Frameshift (deletion) mutation. With the deletion of a single nucleotide, in this case the G in the second codon, a shift of the reading frame occurs. Notice how the sequence of amino acids has changed from the point of the deletion and beyond. Although not illustrated here, this type of frameshift mutation can result in the introduction of a premature stop codon and thus a truncated protein. Insertion mutations also can produce similar effects on the reading frame.

extremely helpful in molecular techniques used to elucidate new gene sequences.¹⁶

Mendelian Inheritance

Single gene disorders are generally inherited in a simple mendelian fashion and are also called *mendelian diseases* with autosomal dominant, autosomal recessive, X-linked recessive, or X-linked dominant inheritance patterns. This group of disorders accounts for 5% to 10% of pediatric hospital admissions.⁵ Mendelian diseases may manifest in the newborn period and early childhood (Figure 1). Important examples include sickle cell disease, affecting 1 in 400 African Americans in the United States, and cystic fibrosis, seen in about 1 in 2500 Caucasians of northern European ethnicity. Other relevant single gene disorders may manifest in adolescence and adulthood, such as hemochromatosis with a homozygote frequency of 1 in 300 and familial hypercholesterolemia with a frequency of 1 in 500.

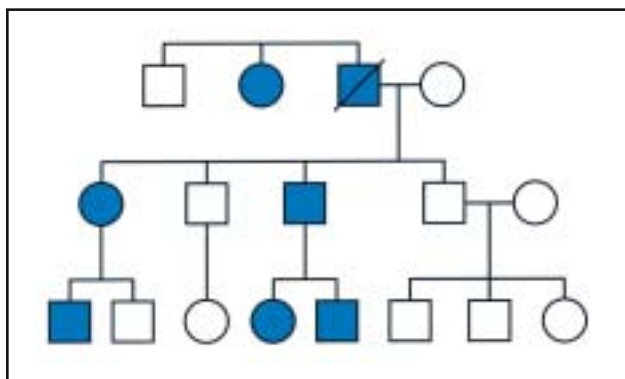

Figure 6. Autosomal dominant inheritance pattern. Affected individuals are indicated by the solid blue symbols.

Patterns of Transmission.—The 4 most common patterns of mendelian inheritance are based primarily on 2 factors: on which type of chromosome (autosome or sex chromosome) the gene locus is found and whether the phenotype is expressed only when both chromosomes of a pair carry the abnormal allele (recessive) or whether the phenotype can be expressed when just 1 chromosome carries the mutant allele (dominant).^{4,5,15,18}

Autosomal Dominant.—In an autosomal dominant disorder, only 1 copy of a gene pair needs to be altered for clinical symptoms to manifest (heterozygous). Examples are familial breast cancer, neurofibromatosis type I, achondroplasia, and congenital long QT syndrome. Each child has a 1 in 2 likelihood of inheriting the mutant allele from an affected parent. The actual risk of being affected with clinical symptoms of the disorder depends on the penetrance of the pathogenic gene and the expressivity of the condition.

Typical features of an autosomal dominant inheritance pattern include the multigenerational presence of symptoms (vertical transmission) and equal involvement of sexes (Figure 6). Individuals may present with recognizable clinical pictures in the absence of an antecedent family history, reflecting new mutations. Dominant conditions often are caused by aberrant structural or developmental processes, and only a minority result from enzymatic defects (eg, the common form of porphyria). A single mutation within a gene can cause a dominant disorder with involvement of multiple organ systems (pleiotropy).

Autosomal Recessive.—In an autosomal recessive disorder, both maternally derived and paternally derived genes (ie, both alleles) must be altered for the clinical phenotype to manifest (homozygous). Examples are hemochromatosis, cystic fibrosis, and sickle cell disease. Each

parent is generally a carrier harboring 1 abnormal allele. Consequently, each child of 2 carriers of a condition has a 1 in 4 risk of inheriting both mutant alleles (and hence the disease phenotype), a 1 in 2 risk of being a carrier, and a 1 in 4 risk of receiving 2 normal copies of the gene. If an individual in one generation is known to be affected with a recessive condition, the likelihood of an apparently unaffected sibling being a carrier is 2 in 3, whereas there remains a 1 in 3 chance that he or she has no mutant allele. Each offspring from an affected parent (who is homozygous for the gene mutation) will be an obligate carrier, assuming that the other parent is not similarly affected by the same disease or a carrier of the disease-causing gene mutation.

Typical features of an autosomal recessive inheritance pattern include generally unaffected heterozygotes (carriers), equal involvement of both sexes, and affected individuals in the same single generation, with absence of disease appearing in multiple generations (Figure 7). Typically, the probability that 2 individuals who are carriers for the same mutation will mate is low; however, this depends on the occurrence of consanguinity and the carrier frequency in the population. For example, heterozygotes for cystic fibrosis are common in the northern European Caucasian population, as are carriers for Tay-Sachs disease in the Ashkenazi Jewish population and for sickle cell disease in individuals of African descent.

Pseudodominant.—In populations with high frequencies of heterozygotes for autosomal recessive conditions, such as in geographically isolated communities, the mating of a homozygote with a heterozygote may result in an inheritance pattern mimicking dominant inheritance (pseudodominance) (Figure 8).

X-Linked Recessive.—All males with an X-linked recessive mutation typically are affected clinically; symptomatic females are rare. Thus, X-linked recessive disease is generally limited to males except for the occasional heterozygous female with clinical manifestations, eg, those with fragile X syndrome, ornithine transcarbamoylase deficiency, or Duchenne muscular dystrophy. The likelihood of a female expressing an X-linked recessive mutation varies for specific disease. Random inactivation of 1 of the 2 X chromosomes in each cell occurs in females early in embryonic development (lyonization).¹⁹ Depending on the collective degree of inactivation of the mutant allele on a single X chromosome in the organ or organ system in which the gene is normally expressed, X chromosome mosaicism may result in clinical effects that are obvious, only minimally detectable, or clinically dormant.

All daughters of an affected male are carriers of the mutated allele, and the risk for any of the daughters' sons to inherit the gene responsible for the condition is 1 in 2. In

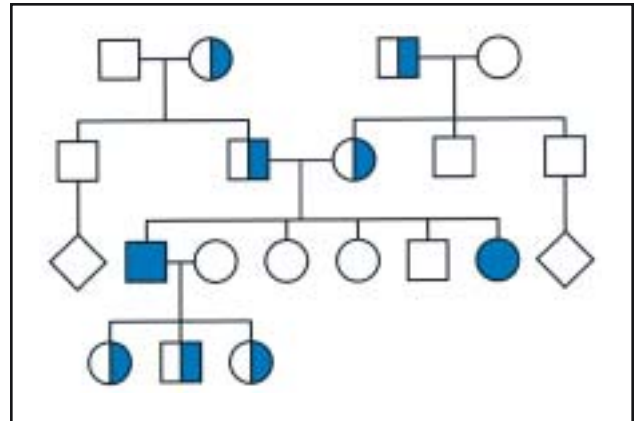

Figure 7. Autosomal recessive inheritance pattern. Affected individuals are indicated by the solid blue symbols. Note that both parents of an affected child are heterozygotes (designated by half-filled blue symbols), as are all the children of a mating between an affected individual and a homozygous normal individual.

contrast, an affected male cannot transmit the mutated allele to any of his sons except in special circumstances.

Typical features of an X-linked recessive inheritance pattern include a higher incidence of the condition in males and usually unaffected female carriers (Figure 9). Isolated cases may be caused by new mutations.

X-Linked Dominant.—In general, both male and female heterozygotes with an X-linked dominant defect are affected clinically. Random X-inactivation would result in less severely affected females, unless they are homozygous for the disease allele. In some X-linked dominant conditions, affected males are rarely or never seen because of a lethal effect of the mutant allele in the hemizygous male. Disorders with an X-linked dominant inheritance pattern are X-linked hypophosphatemic rickets and incontinentia pigmenti.

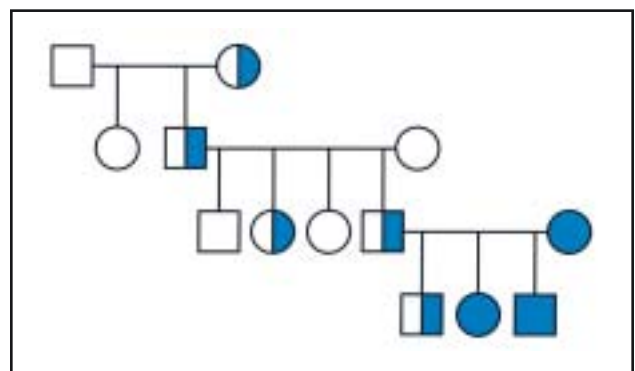

Figure 8. Pseudodominant inheritance pattern. Affected individuals are indicated by the solid blue symbols, carriers by the half-filled symbols.

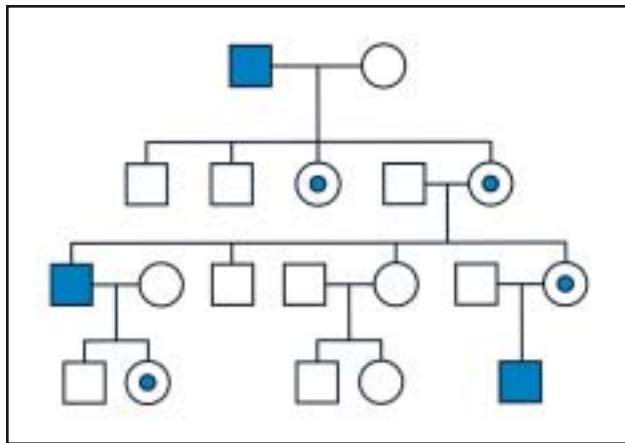

Figure 9. X-linked recessive inheritance pattern. Affected individuals are indicated by the solid blue symbols. Heterozygotes are indicated by the blue dot inside the circle.

In X-linked dominant inheritance, both male and female children have a 1 in 2 risk of inheriting the mutant allele from the affected mother and thus being affected as well. Sons of an affected male do not inherit the condition, whereas all daughters are affected clinically.

Typical features of an X-linked dominant inheritance pattern include multigenerational manifestation, presence of symptoms in all the daughters and none of the sons of an affected male, and equal involvement of both sexes when transmitted by females (Figure 10).

Nonmendelian Inheritance Patterns

Clinical investigation of certain unusual conditions that did not appear to follow classic mendelian modes of inheritance and detailed molecular studies of mutations

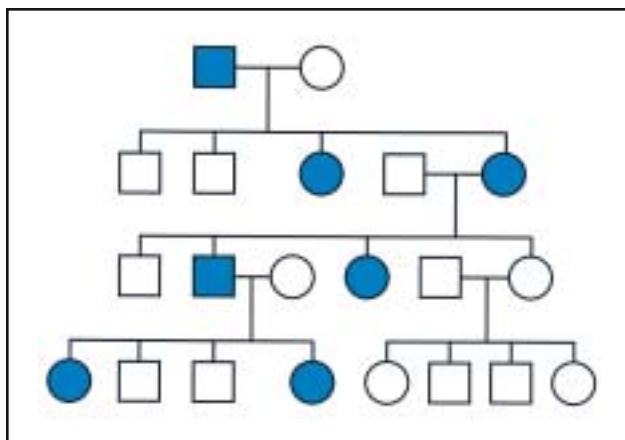

Figure 10. X-linked dominant inheritance pattern. Affected individuals are indicated by the solid blue symbols.

have led to the elucidation of nonmendelian inheritance patterns.^{4,5,15,18}

Genomic Imprinting.—Differential expression of genes depending on whether the mutant allele is of maternal or paternal origin results from genomic imprinting.²⁰ The underlying mechanism leads to an alteration in chromatin affecting gene expression without changing its sequence. Therefore, the gene is not necessarily mutated but reversibly inactivated, usually by a process of methylation.

During gametogenesis, before fertilization, specific genes are marked (“imprinted”) as maternally or paternally inherited. The imprint results in transcriptional inactivation of the imprinted allele and remains stable through multiple cell divisions. However, this process is reversible. For example, in male gametes a maternally imprinted allele must be newly marked as paternal so it can be passed on as a paternally imprinted allele. The imprinting center is a chromosome segment that controls this conversion within the imprinted region itself.

The presence of 2 intact chromosomes derived from 1 parent is called *uniparental disomy* (UPD). Isodisomy refers to the presence of a duplicated copy of 1 chromosome from a parent, whereas heterodisomy refers to 2 homologous chromosomes from 1 parent. When UPD for specific imprinted chromosome regions is present, clinical symptoms may manifest.

Classic examples of disorders involving imprinting mechanisms are Prader-Willi syndrome (PWS) and Angelman syndrome (AS); both involve the chromosome region 15q11-q13. Individuals with PWS have hyperphagia, obesity, small hands and feet, short stature, and variable mental retardation, whereas those with AS present with movement abnormalities, seizures, severe mental retardation, sleep disorders, and a characteristic abnormal facial expression. Both PWS and AS are the result of loss of paternally and maternally imprinted genes on 15q11-q13, respectively. In both conditions, 70% of cases are caused by a deletion on the allele inherited from the father (PWS) or the mother (AS) (Table 1). Approximately 30% of patients with PWS have 2 maternal chromosomes 15 (maternal UPD), and only 3% to 5% of patients with AS have 2 paternal chromosomes 15 (paternal UPD). In the rest of the patients, particularly those with AS, other molecular mechanisms have been found to be causative (Table 1).

Mosaicism.—Mosaicism is the presence of at least 2 cell lines within an individual or a specific tissue that differ genetically but are derived from a single fertilized egg. Depending on the stage of embryonic development, mosaicism may be present in somatic or germ cell lines or both, and there is substantial clinical variability. An example of mosaicism is seen in chromosome disorders. Pigmentary mosaicism, sometimes called *hypomelanosis of Ito*, de-

scribes a clinical picture of skin hypopigmentation and hyperpigmentation that follows the curvilinear lines of Blaschko.²³ Chromosome mosaicism is commonly detected in skin fibroblasts in patients with these findings.^{24,25}

The clinical consequences of single gene mosaicism depend on the type of the mutation and the extent of tissue involvement. The occurrence of somatic mutations has been recognized as a major cause of many types of cancers. Either somatic or germline mosaicism for single gene mutations may be the underlying etiology in families with unusual clinical pictures and/or pedigrees. Segmental phenotypes have been described in patients with neurofibromatosis,²⁶ and a patchy phenotype is known for McCune-Albright syndrome.²⁷ Milder phenotypes can be observed in patients with mild mosaic osteogenesis imperfecta whose newborn may have a severe form.²⁸ This variability between parent and child may be due to differences in the percentage of cells containing the gene mutation.

Mitochondrial Disorders.—Mitochondria are the major site of adenosine triphosphate production via oxidative phosphorylation. Mitochondrial disorders are clinically heterogeneous associated with mutations of either nuclear DNA or mitochondrial DNA (mtDNA).²⁹⁻³¹ Nuclear gene defects are primarily inherited in an autosomal recessive manner.

Comprising 16,569 nucleotides, mtDNA is circular, double-stranded, and located inside the mitochondria. Considering that the ovum (not the sperm) provides the zygote with almost all its mitochondria, mtDNA defects have been assumed to follow a strictly maternal inheritance pattern. However, paternal inheritance of mtDNA was recently shown in a patient with respiratory chain complex I deficiency and a sporadic mtDNA deletion.³² Generally, mtDNA deletions occur sporadically, whereas mtDNA point mutations and duplications can be transmitted maternally.

In contrast to chromosomes in the nuclear genome, there is no tightly controlled segregation of the mtDNA. At cell division, the mtDNA replicates and sorts randomly among mitochondria, which are also distributed randomly among the 2 resultant (daughter) cells. *Homoplasmy* refers to a situation in which all mitochondria in each cell have the same DNA, whereas *heteroplasmy* describes the presence of different populations of mtDNA molecules in a cell.³³ The percentage of the mtDNA with an alteration can influence the variability of the condition. A female with a heteroplasmic point mutation may transmit a variable amount of mutant mtDNA to her children, which may lead to pronounced intrafamilial phenotypic variability. Thus, recurrence risk for offspring is variable and difficult to predict.

Triplet Repeat Disorders.—Triplet repeat disorders are the most common group of diseases that are caused by

Table 1. Molecular Mechanisms Underlying Prader-Willi and Angelman Syndromes^{21,22*}

Mechanism	Angelman syndrome (%)	Prader-Willi syndrome (%)
15q11-q13 deletion	About 70 (maternal)	About 70 (paternal)
Uniparental disomy	About 3-5 (paternal)	About 30 (maternal)
Single gene mutation	2-4 (<i>UBE3A</i> mutation)	ND
Imprinting center mutation	7-9	1-2
Unknown	10-20	ND

*ND = none detected; *UBE3A* = gene for E6-AP ubiquitin-protein ligase.

unstable dynamic mutations in a gene.^{34,35} In these disorders, a segment of DNA containing a repeat of 3 nucleotides (triplet repeats or trinucleotide repeats) increases in number when passed from generation to generation, undergoing expansion. Subsequently, after a critical degree of expansion, changes in gene expression and function occur, yielding a disease phenotype. This mutational mechanism underlies 14 neurologic disorders, including fragile X syndrome, spinobulbar muscular atrophy, myotonic dystrophy, Friedreich ataxia, and Huntington disease.³⁶

MULTIFACTORIAL DISORDERS

Many genetic disorders appear familial but do not follow a single gene pattern of inheritance. These multifactorial (polygenic, complex) disorders are the result of a combination of alterations in multiple genes with varying degrees of effect that act in concert with environmental factors, thus producing a clinical phenotype when a developmental threshold is reached.³⁷ The genetic heterogeneity seen in complex disorders may result from different mutations at the same gene locus or as a result of mutations at different loci or both.³⁸ Examples include common diseases, such as hypertension and diabetes mellitus, and birth defects, such as cleft lip/palate. Approximately one half of all congenital disorders are thought to be multifactorial conditions.⁴ In general, the empirical recurrence risk is reported to be no more than 5% to 10%, although the exact recurrence risk for certain multifactorial conditions may be variable.³⁹

In contrast to the increasing compendium of genes responsible for monogenic disorders, in the past 2 decades, relatively few genes have been identified with a substantial role in complex genetic disorders.^{38,40} Phenotypic modification occurs when expression of a certain gene results in alteration of the clinical presentation normally conferred by another gene. Identification of such modifier genes and single nucleotide polymorphisms appears to be helpful in simplifying the analysis of complex traits.⁴¹ Although cur-

rent research tries to elucidate the interaction of genes and the phenotypic consequences, analysis of the complex interactions between genes and the environment still remains a future goal.

POPULATION GENETICS

Population genetics is the study of gene diversity in different populations and the changes of the frequency of genes and genotypes over time. Population genetic studies attempt to provide knowledge about the importance (or lack thereof) of different disease genes in different populations, the value of carrier screening programs, and the effect of treatment on the population frequency of a disease.

The Hardy-Weinberg principle represents a model for calculating genotype frequencies from allele frequencies for a random mating population in equilibrium.^{4,5} If only 2 alleles at a single locus were considered, occurring at frequencies p and q with $p = 1 - q$, the frequency of homozygosity for either allele would be p^2 or q^2 . One of the major applications of this principle is the calculation of the carrier frequency in a population for which the disease frequency is established. If, for example, 1 in 10,000 is considered as the incidence for homozygotes with phenylketonuria (PKU), this would represent q^2 ; q then would become 1 in 100. The frequency of homozygosity for the normal allele at the same locus is p^2 . Given that $p = 1 - q$, p becomes 99 in 100, and p^2 equals 9801 in 10,000. The frequency of heterozygotes is $2pq$ and equals 1 in 50 (ie, 2×99 in 100×1 in 100). Thus, the carrier frequency of a condition that occurs in 1 in 10,000 individuals in a homozygous state, such as PKU, is 1 in 50 or 2%.

Even for rare autosomal recessive disorders, the frequency of carrying 1 mutant allele is relatively high. For genetic conditions with incidences greater than for PKU, such as sickle cell disease for individuals of African ancestry (1 in 400), the carrier frequency is much higher. However, the Hardy-Weinberg principle is based on large populations with random mating and the absence of selection, mutation, or migration. Thus, if there is deviation from any of these factors, such as consanguinity or ethnic isolation, alterations in allele frequencies will result in subsequent generations. In these cases, the allelic frequencies in a population may not be in Hardy-Weinberg equilibrium, and thus the principle is inapplicable.

DIAGNOSIS OF GENETIC DISEASE

With improving therapeutic management in all medical fields, children who earlier might have died as infants because of tetralogy of Fallot or cystic fibrosis now have increased survival and come to the attention of medical specialists other than pediatricians. Additionally, with our increased understanding of the hereditary basis of common

adult conditions, such as some cancers and coagulopathies (eg, factor V Leiden), genetic conditions are common in adult medical practice as well. Thus, care providers need to familiarize themselves with genetic conditions and/or birth defects, which may affect their patients.

Even though the number and variety of genetic conditions might be intimidating, the skills required to make a genetic diagnosis are similar to those used for more common health problems, including history taking, physical examination, and proper laboratory testing.^{42,43}

Personal History

Questions regarding current and/or past medical history relevant to the patient's presentation should be asked. Abnormal results of common laboratory analyses (eg, coagulation profiles or iron studies) may suggest a genetic condition.

The pregnancy history of the patient's mother might disclose maternal disease potentially causative of or related to the fetal condition, as seen in certain metabolic disorders such as untreated maternal PKU⁴⁴ or fatty acid oxidation disorders.⁴⁵ Sometimes, environmental exposures during pregnancy can explain the fetal phenotype, such as in fetal alcohol syndrome.⁴⁶

Family History

A thorough family history includes detailed information on relatives' ages, current and past medical health (including developmental or learning problems), birth defects, obvious dysmorphism, and surgeries. Specifically, questions about miscarriages, stillbirths, and infant deaths, as well as infertility, should be asked. For deceased family members, age and cause of death should be documented. The racial and ethnic background is of importance in identifying higher risk groups. In addition, the possibility of consanguinity in the family history should be explored when clinically relevant.⁴⁷

Drawing a family tree (pedigree) that symbolically represents the family and demonstrates relationships between affected family members is an efficient and highly informative exercise. In general, a 3-generation pedigree is sufficient, unless the patient mentions pertinent symptoms in more distant relatives.

Family photographs or medical records may be of help, particularly if other family members are suspected to have the same genetic disorder.

Physical Examination

A genetic disorder might be suspected when the patient presents with developmental delays or mental retardation, birth defects, microcephaly, short stature, or failure to thrive. The combination of "unusual" dysmorphic features

may lead to a specific syndrome diagnosis or at least prompt further laboratory testing and referral to a specialist in medical genetics.

Laboratory Testing

Genetic testing refers to cytogenetic, molecular genetic, and biochemical analyses. Each category comprises multiple different specialized tests. Before these tests are ordered, information should be obtained on the type and volume of the specimen required (blood, urine, cerebrospinal fluid, fibroblasts, amniocytes), type of tube in which the specimen should be kept, and conditions under which the specimen should be sent. Many genetic tests are available only in specialized laboratories, and it is important to have a good working understanding of the methods used in each of these laboratories so that the laboratory most suited for a specific patient can be used.

Cytogenetic Testing.—Cytogenetic testing primarily includes chromosome analysis. Tissues most commonly used are lymphocytes and amniocytes. The Giemsa stain results in a banding pattern (G-bands) specific to each chromosome and thus is used for evaluation. Commonly, this procedure is modified by the use of trypsin and Leishman stain. In case of a normal karyotype and depending on the band resolution, further cytogenetic testing for more subtle or cryptic chromosome rearrangements might be pursued. This might include subtelomeric FISH studies to screen for cryptic anomalies involving the ends of the chromosomes and/or FISH tests for microdeletion syndromes, such as deletions on 4p (Wolf-Hirschhorn syndrome), 5p (cri du chat syndrome), or 22q (DiGeorge/velocardiofacial syndrome). Also, FISH studies can be helpful in identifying disorders caused by “microduplication syndromes,” and a classic example is Charcot-Marie-Tooth disease type IA resulting from a partial duplication of 17p.

A high rate of cytogenetic abnormalities can be detected in cancer cells, and for some cancer types, such as leukemias and lymphomas, the specific karyotype can provide diagnostic and prognostic information.

Molecular Genetic Testing.—DNA testing investigates alterations in a gene that result in disease. Several techniques have been developed recently, including polymerase chain reaction, Southern blot analysis, restriction enzyme analysis, and sequencing. The finding of a disease-causing mutation confirms the suspected clinical diagnosis, identifies a disease carrier, or shows a pronounced genetic predisposition to disease. Examples of clinically available molecular genetic tests include those for cystic fibrosis, fragile X syndrome, *BRCA1* and *BRCA2* breast/ovarian cancer susceptibility, and factor V Leiden. Direct mutation testing is also used to diagnose triplet expansion diseases.

Linkage analysis is a form of indirect DNA testing used (1) when only the location of a gene is known but not the gene itself or (2) when currently available direct gene testing has been unable to detect a mutation, although the gene location has been identified. Linkage testing investigates polymorphisms around or within a gene and their transmission through the family, thereby identifying with a high degree of certainty who has and who has not inherited the “disease allele.” However, linkage analysis is most informative for patients and families who have a highly affected family (ie, a multigenerational pedigree with several unambiguously affected individuals) with multiple relatives available to test. This technique is used in genomics research but only occasionally in clinical practice.

For some disorders, testing of the affected protein is easier than DNA analysis. This is true for connective tissue disorders, such as osteogenesis imperfecta (type I collagen). Testing requires a fibroblast culture for osteogenesis imperfecta and some other conditions.

Most molecular genetic tests are labor intensive and time consuming. Thus, depending on the rarity of the disease, results might become available after a few weeks to months. Many molecular genetic tests also have limited detection rates; thus, it is extremely important to have a good understanding of the limitations of the testing to interpret the results accurately.

Biochemical Testing.—Biochemical testing refers to analyses of metabolites that are either the substrates or the products of a deficient enzyme. Thus, increases or decreases of metabolite concentrations are indirect indicators of metabolic disorders caused by an enzyme deficiency. Plasma ammonia, lactate, pyruvate, glucose and bicarbonate, plasma amino acids, and urine organic acids should be analyzed routinely if metabolic disease is suspected.⁴⁸ Additional testing might include analyses of plasma acylcarnitines and carnitine, urine acylglycines, urine purines/pyrimidines, plasma peroxisomal fatty acids, urine mucopolysaccharides, plasma cholesterol metabolites, and many other metabolites depending on the clinical presentation of the patient.

If abnormal metabolites are identified, the disease may then be confirmed by enzyme analysis when available. Enzyme analysis often requires a fibroblast culture or a fresh liver biopsy. Some enzyme tests can be done on serum, red blood cells, or leukocytes.

Genetic Counseling

After a complete diagnostic evaluation, a definitive genetic diagnosis may or may not be made. In either case, appropriate genetic counseling is imperative to assist the patient and the family in gaining a proper understanding of the assessment. Genetic counseling is a communication

process that deals with human problems associated with the occurrence or risk of occurrence of a genetic disorder in a family.^{49,50} The results of the diagnostic evaluation are explained completely. Education is provided about the particular genetic disease and its implications. An assessment of risk for the patient and family members is discussed on the basis of the known inheritance patterns or empirical risks (if no obvious genetic diagnosis has been made). If the family is concerned about reproductive implications and risks for offspring, these issues are addressed. The psychosocial implications of the diagnostic evaluation/risk assessment are also explored with the patient/family. A key component of genetic counseling is that these discussions are held with the utmost respect and concern for the patient's/family's psychosocial, spiritual, cultural, and moral context.

CONCLUSION

Genetics, genomics, pharmacogenetics, pharmacogenomics, and pathogenomics will undoubtedly play a key role in this post-Human Genome Project era of medicine now under way. The profound heterogeneity and variability observed in the clinical phenotype of once well-understood monogenic disorders underscore the complexity of this field. The search is under way for genetic variants rendering a measurable degree of susceptibility for the development of complex multifactorial diseases common among humans, such as hypertension, congestive heart failure, and cancer. Our hope is that this article has provided the essentials of medical genetics that are relevant and necessary at the present time: namely, a framework so that clinicians can "speak the language" of the new genomics and integrate this knowledge into their clinical practice.

GLOSSARY OF SOME TERMS USED IN MEDICAL GENOMICS

Alleles—Reciprocal forms of genetic information at a precise locus within a gene. The variability between 2 alleles can represent differences in a single nucleotide or a larger segment of DNA sequence. The normal version of genetic information is often referred to as the *wild-type* or *normal* allele. The DNA from one individual is largely made up of the same exact nucleotide sequence as another individual, and they share more than 99.9% of their DNA sequences.⁵¹ However, there are many small sections of sequence, or even single nucleotides, that differ from one individual to another. These normal variations at particular loci in the DNA sequence are called *polymorphisms*. Some variations are common, and others represent rare variants of the genetic information. In medical genetics, a disease-causing mutation refers to a variation in DNA sequence that represents an abnormal allele.

Expressivity—Degree of expression of the phenotype in individuals who have mutations in the same gene. This variability can occur within families (even though they share the same genotype, likely because of differences in other "background" modifier

genes and environmental effects) and between families (perhaps because of genotype-phenotype variability). When the manifestations of the phenotype in individuals who have the same genotype are different, the phenotype is said to have variable expressivity. Reduced penetrance and variable expressivity pose a major challenge for interpreting pedigrees, making a proper diagnosis, determining risk, and providing genetic counseling regarding the disorder.

Genotype—Individual's genetic or DNA sequence makeup at a particular locus or at a collective body of loci.

Hemizygote—Individual who has only 1 copy of a gene or DNA sequence in diploid cells, eg, males are hemizygous for most genes on the sex chromosomes.

Heterozygote—Individual with different alleles.

Homozygote—Individual with a pair of identical alleles, 1 maternal and 1 paternal.

Penetrance—Probability that a gene will have any expression at all at any time in the individual's life span. When the frequency of phenotypic expression is less than 100%, the gene is said to show reduced or incomplete penetrance.

Phenotype—Individual's observed clinical expression of disease in terms of a morphologic, biochemical, or molecular trait. In many genetic disorders, the abnormal phenotype can be clearly distinguished from the normal one. However, in some disorders, the abnormal phenotype is completely absent in individuals harboring the disease-causing mutation, whereas other individuals show extremely variable expression of phenotype in terms of clinical severity, age at onset, and response to therapy.

For definition of other terms frequently used in medical genomics, see Tefferi et al.⁵²

REFERENCES

- Lie RT, Wilcox AJ, Skjaerven R. A population-based study of the risk of recurrence of birth defects. *N Engl J Med*. 1994;331:1-4.
- Baird PA, Anderson TW, Newcombe HB, Lowry RB. Genetic disorders in children and young adults: a population study. *Am J Hum Genet*. 1988;42:677-693.
- Hall JG, Powers EK, McIlvaine RT, Ean VH. The frequency and financial burden of genetic disease in a pediatric hospital. *Am J Med Genet*. 1978;1:417-436.
- Rimoin DL, Connor JM, Pyeritz RE, Korf BR. Nature and frequency of genetic disease. In: Rimoin DL, Connor JM, Pyeritz RE, Korf BR, eds. *Emery and Rimoin's Principles and Practice of Medical Genetics*. Vol 1. 4th ed. New York, NY: Churchill Livingstone; 2002:55-59.
- Gelehrter TD, Collins FS, Ginsburg D. *Principles of Medical Genetics*. 2nd ed. Baltimore, Md: Williams & Wilkins; 1998:1-42.
- Tolmie JL. Chromosome disorders. In: Whittle MJ, Connor JM, eds. *Prenatal Diagnosis in Obstetric Practice*. 2nd ed. Oxford, England: Blackwell Science; 1995:34-57.
- Pellestor F. Frequency and distribution of aneuploidy in human female gametes. *Hum Genet*. 1991;86:283-288.
- Flint J, Wilkie AO, Buckle VJ, Winter RM, Holland AJ, McDermid HE. The detection of subtelomeric chromosomal rearrangements in idiopathic mental retardation. *Nat Genet*. 1995;9:132-140.
- Knight SJ, Regan R, Nicod A, et al. Subtle chromosomal rearrangements in children with unexplained mental retardation. *Lancet*. 1999;354:1676-1681.
- Ravnan JB. Summary of subtelomeric fish analysis on over 2000 specimens in one laboratory. *Genet Med*. In press.
- Jalal SM, Harwood AR, Sekhon GS, et al. Utility of subtelomeric fluorescent DNA probes for detection of chromosome anomalies in 425 patients. *Genet Med*. 2003;5:28-34.

12. National Center for Biotechnology Information. Online Mendelian Inheritance in Man (OMIM). Available at: www.ncbi.nlm.nih.gov/omim/. Accessibility verified May 21, 2003.
13. Lander ES, Linton LM, Birren B, et al. Initial sequencing and analysis of the human genome [published corrections appear in *Nature*. 2001;411:720 and *Nature*. 2001;412:565]. *Nature*. 2001;409:860-921.
14. Strachan T, Read AP. *Human Molecular Genetics* 2. 2nd ed. New York, NY: Wiley-Liss; 1999:209-240.
15. Nussbaum RL, McInnes RR, Willard HF. *Thompson & Thompson Genetics in Medicine*. 6th ed. Philadelphia, Pa: WB Saunders Co; 2001:51-78, 79-94.
16. Guttmacher AE, Collins FS. Genomic medicine—a primer. *N Engl J Med*. 2002;347:1512-1520.
17. Harris A. Cystic fibrosis gene. *Br Med Bull*. 1992;48:738-753.
18. Sack GH Jr. *Medical Genetics*. New York, NY: McGraw-Hill; 1999:97-166.
19. Brown CJ, Robinson WP. The causes and consequences of random and non-random X chromosome inactivation in humans. *Clin Genet*. 2000;58:353-363.
20. Reik W, Walter J. Genomic imprinting: parental influence on the genome. *Nat Rev Genet*. 2001;2:21-32.
21. Jiang Y, Tsai TF, Bressler J, Beaudet AL. Imprinting in Angelman and Prader-Willi syndromes. *Curr Opin Genet Dev*. 1998;8:334-342.
22. Nicholls RD, Saitoh S, Horsthemke B. Imprinting in Prader-Willi and Angelman syndromes. *Trends Genet*. 1998;14:194-200.
23. Happle R. Mosaicism in human skin: understanding the patterns and mechanisms. *Arch Dermatol*. 1993;129:1460-1470.
24. Kuster W, Konig A. Hypomelanosis of Ito: no entity, but a cutaneous sign of mosaicism. *Am J Med Genet*. 1999;85:346-350.
25. Sybert VP. Hypomelanosis of Ito: a description, not a diagnosis. *J Invest Dermatol*. 1994;103(suppl 5):141S-143S.
26. Ruggieri M, Huson SM. The clinical and diagnostic implications of mosaicism in the neurofibromatoses. *Neurology*. 2001;56:1433-1443.
27. Tinschert S, Gerl H, Gewies A, Jung HP, Nurnberg P, McCune-Albright syndrome: clinical and molecular evidence of mosaicism in an unusual giant patient. *Am J Med Genet*. 1999;83:100-108.
28. Zlotogora J. Germ line mosaicism. *Hum Genet*. 1998;102:381-386.
29. Leonard JV, Schapira AH. Mitochondrial respiratory chain disorders, I: mitochondrial DNA defects. *Lancet*. 2000;355:299-304.
30. Leonard JV, Schapira AH. Mitochondrial respiratory chain disorders, II: neurodegenerative disorders and nuclear gene defects. *Lancet*. 2000;355:389-394.
31. Vu TH, Hirano M, DiMauro S. Mitochondrial diseases. *Neurol Clin*. 2002;20:809-839.
32. Schwartz M, Vissing J. Paternal inheritance of mitochondrial DNA. *N Engl J Med*. 2002;347:576-580.
33. Chinnery PF, Turnbull DM. Mitochondrial DNA and disease. *Lancet*. 1999;354(suppl 1):SI17-SI21.
34. Cummings CJ, Zoghbi HY. Trinucleotide repeats: mechanisms and pathophysiology. *Annu Rev Genom Hum Genet*. 2000;1:281-328.
35. Masino L, Pastore A. A structural approach to trinucleotide expansion diseases. *Brain Res Bull*. 2001;56:183-189.
36. Lindblad K, Schalling M. Expanded repeat sequences and disease. *Semin Neurol*. 1999;19:289-299.
37. Peltonen L, McKusick VA. Genomics and medicine: dissecting human disease in the postgenomic era. *Science*. 2001;291:1224-1229.
38. Glazier AM, Nadeau JH, Aitman TJ. Finding genes that underlie complex traits. *Science*. 2002;298:2345-2349.
39. Yaron Y, Orr-Urtreger A. New genetic principles. *Clin Obstet Gynecol*. 2002;45:593-604.
40. Badano JL, Katsanis N. Beyond Mendel: an evolving view of human genetic disease transmission. *Nat Rev Genet*. 2002;3:779-789.
41. Matin A, Nadeau JH. Sensitized polygenic trait analysis. *Trends Genet*. 2001;17:727-731.
42. Scheuerle AE. Diagnosis of genetic disease. In: Fathman L, ed. *Genetics in the Clinic: Clinical, Ethical, and Social Implications for Primary Care*. St Louis, Mo: Mosby; 2001:15-29.
43. McKusick VA. Medical Genetics: a 40-year perspective on the evolution of a medical specialty from a basic science. *JAMA*. 1993;270:2351-2356.
44. Rouse B, Azen C, Koch R, et al. Maternal Phenylketonuria Collaborative Study (MPKUCS) offspring: facial anomalies, malformations, and early neurological sequelae. *Am J Med Genet*. 1997;69:89-95.
45. Rinaldo P, Studinski AL, Matern D. Prenatal diagnosis of disorders of fatty acid transport and mitochondrial oxidation. *Prenat Diagn*. 2001;21:52-54.
46. Thackray H, Tiff C. Fetal alcohol syndrome. *Pediatr Rev*. 2001;22:47-55.
47. Bittles A. Consanguinity and its relevance to clinical genetics. *Clin Genet*. 2001;60:89-98.
48. Rinaldo P, Matern D. Biochemical diagnosis of inborn errors of metabolism. In: Rudolph CD, Rudolph AM, Hostetter MK, Lister G, Siegel NJ, eds. *Rudolph's Pediatrics*. 21st ed. New York, NY: McGraw-Hill; 2002:578-583.
49. American Society of Human Genetics. Genetic counseling. *Am J Hum Genet*. 1975;27:240-242.
50. Biesecker BB. Goals of genetic counseling. *Clin Genet*. 2001;60:323-330.
51. Venter JC, Adams MD, Myers EW, et al. The sequence of the human genome. *Science*. 2001;291:1304-1351.
52. Tefferi A, Wieben ED, Dewald GW, et al. Primer on medical genomics, part II: background principles and methods in molecular genetics. *Mayo Clin Proc*. 2002;77:785-808.

Primer on Medical Genomics Part IX will appear in the September issue.